

Click to
ORDER
samples

AMEL90-277HAVZ



The AMEL90-277HAVZ series is an efficient 90W AC-DC power supply module. Offering a commercial input voltage range of 85-305VAC, output voltage ranges from 12-48V, low power consumption up to 0.21W, high efficiency, high reliability and safer isolation.

This new series offers great operating temperatures, from -40°C to 85°C with full power up to 50°C and features an isolation of 4000VAC for improved reliability and system safety. Furthermore, a high MTBF of 300,000h, output short circuit protection (OSCP), output over-current protection (OCP) and an output over-voltage protection (OVP) come standard with the series.

The AMEL90-277HAVZ is great for grid power, industrial instrumentation and controls, communication, and civil applications.

Features



- Universal Input: 85 - 305VAC/110 - 430VDC
- Operating Temp: -40 °C to +85 °C
- High isolation voltage: 4000VAC
- Low ripple & noise, 240mV(p-p), max.
- Output short circuit, over-current, over-voltage protection
- Low no-load power consumption of 0.21W
- Efficiency up to 93%
- Certified : EN/BS EN 62368-1, EN60335-1, EN61558-1
- Designed to meet: IEC/UL 62368-1 standards

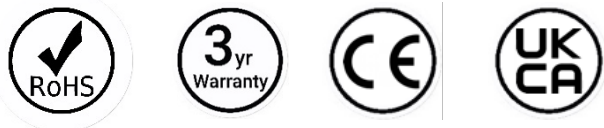

Summary

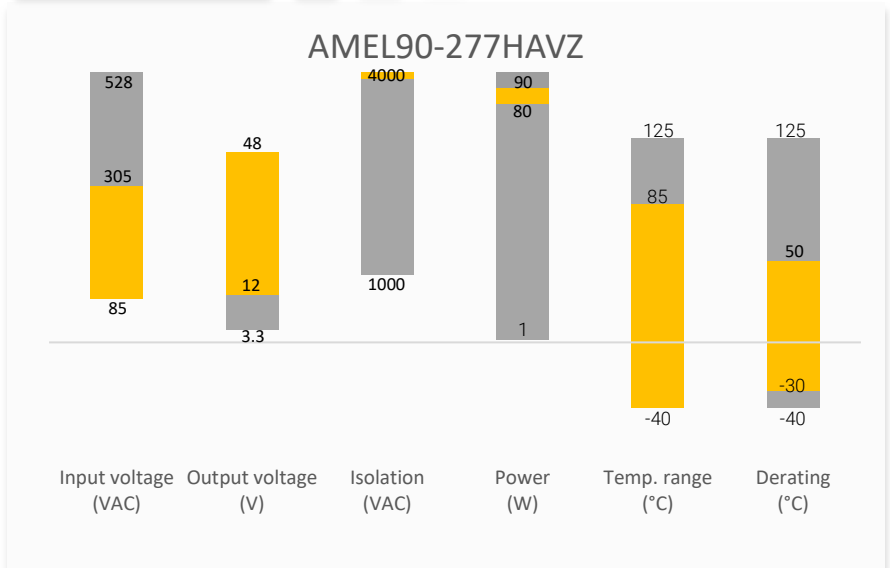

Training



Product Training Video
(click to open)

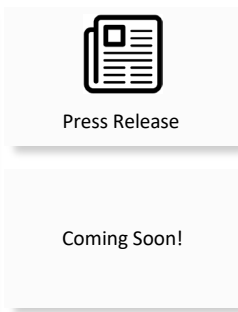

Application Notes

Applications



Power Grid



Industrial



Telecom

Models & Specifications

Single Output

Model	Input Voltage (VAC/Hz)	Input Voltage (VDC)	Max Output wattage (W)	Output Voltage (V)	Output Current max (A)	Maximum capacitive load (μF)	Efficiency @ 230VAC Typ. (%)
AMEL90-12S277HAVZ	85-305/47-63	110-430	80	12	6.7	6800	92
AMEL90-15S277HAVZ	85-305/47-63	110-430	85	15	5.67	4500	92.5
AMEL90-24S277HAVZ	85-305/47-63	110-430	90	24	3.75	3000	93
AMEL90-48S277HAVZ	85-305/47-63	110-430	90	48	1.875	470	93

Input Specifications

Parameters	Conditions	Typical	Maximum	Units
Input current	115VAC		2	A
	230VAC		1.1	A
Inrush current	115VAC	35		A
	230VAC	65		A

Output Specifications

Parameters	Conditions	Typical	Maximum	Units
Voltage accuracy		±2		%
Line regulation	Full load	±0.5		%
Load regulation	0 to 100% load	±1		%
Ripple & Noise*	12V/15V		120	mV p-p
	24V		200	mV p-p
	48V		240	mV p-p
Hold up time	115VAC	10		ms
	230VAC	30		ms

* Ripple and Noise are measured at 20MHz bandwidth. Please refer to the application note for specific details.

Isolation Specification

Parameters	Conditions	Typical	Maximum	Units
Tested I/O voltage	60 sec, leakage ≤ 5mA	4200		VAC

General Specifications

Parameters	Conditions	Typical	Maximum	Units
Protection class	Class II			
Oversvoltage category	OVC III			
Over current protection	Auto recovery	≥ 110		% of Iout
Over voltage protection	12Vout		16	VDC
	15Vout		24	VDC
	24Vout		35	VDC
	48Vout		63	VDC

Short circuit protection	Hiccup, Continuous, Auto recovery		
Switching Frequency		75	KHz
Operating temperature	See power derating	-40 to +85	°C
Storage temperature		-40 to +85	°C
Wave soldering temperature	Duration 5 - 10s	260 ± 5	°C
Manual soldering temperature	Duration 3 - 5s	360 ± 10	°C
No-load power consumption		0.21	W
Power Derating	-40 °C to -30 °C	5	%/°C
	+50 °C to +70 °C	2.5	%/°C
	+70 °C to +85 °C	1.66	%/°C
	80VAC – 100VAC	1	%/VAC
Temperature coefficient	2000m – 4000m	±0.02	%/Km
Cooling	Free air convection		
Humidity	Non-condensing		95 % RH
Case material	Plastic (flammability to UL 94V-0)		
Weight	PCB mountable models	200	g
Dimensions (L x W x H)	PCB mountable models	3.43 x 2.05 x 1.16 inches (87.00 x 52.00 x 29.50 mm)	
MTBF	> 300 000 hrs (MIL-HDBK -217F, t=+25°C)		

NOTE: All specifications in this datasheet are measured at an ambient temperature of 25°C, humidity<75%, nominal input voltage and at rated output load unless otherwise specified.

Safety Specifications		
Parameters		
Agency approvals	EN/BS EN 62368-1, EN60335-1, EN61558-1	
Standards	Information technology Equipment	Designed to meet IEC/UL 62368-1
	EMC - Conducted and radiated emission	CISPR32 / EN55032, class B
	Electrostatic Discharge Immunity	IEC 61000-4-2 Contact ±4KV, Air ±8KV, Criteria B
	RF, Electromagnetic Field Immunity	IEC 61000-4-3 10V/m, Criteria A
	Electrical Fast Transient/Burst Immunity	IEC 61000-4-4 ±2KV, Criteria A IEC 61000-4-4 ±4KV, Criteria B with the recommended EMC circuit
	Surge Immunity	IEC 61000-4-5 L-L ±2KV, L-G ±2KV, Criteria A IEC 61000-4-5 L-L ±4KV, L-G ±4KV, Criteria B with the recommended EMC circuit
	RF, Conducted Disturbance Immunity	IEC 61000-4-6 10Vr.m.s, Criteria A
	Power-frequency Magnetic Field Immunity	IEC 61000-4-8 10A/m, Criteria A
Voltage dips, Short Interruptions Immunity	IEC 61000-4-11 0%, 70%, Criteria B	

Derating

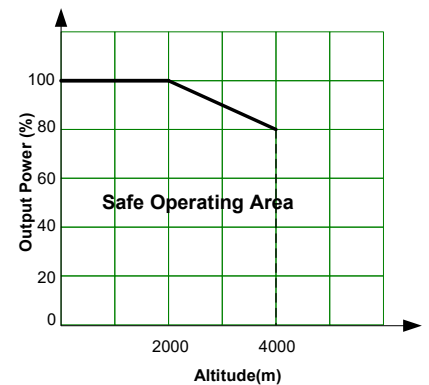
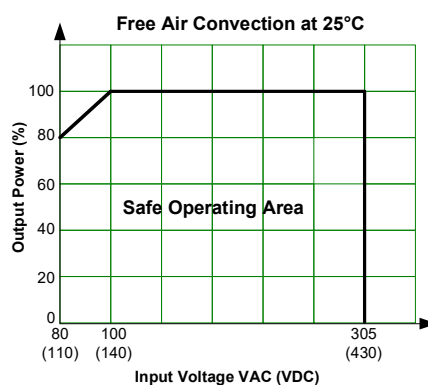
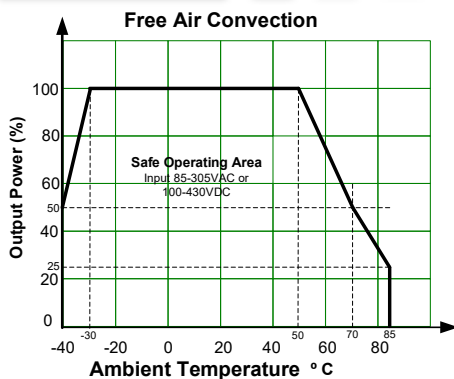

Typical Application Circuit

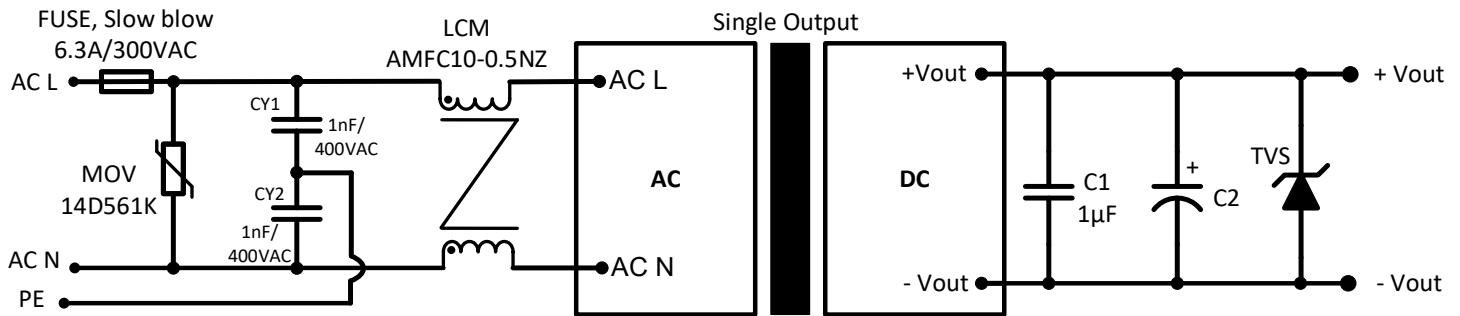

Model	C2	TVS
12, 15Vout	330μF	20V
24Vout	200μF	30V
48Vout	100μF	64V

For filtering components:

Choose capacitors with at least 20% voltage margin. The C2 capacitor is recommended to use electrolytic type with high frequency and low ESR rating. The C1 capacitor is recommended to use ceramic type for filtering high-frequency noise.

Recommended EMC Circuit

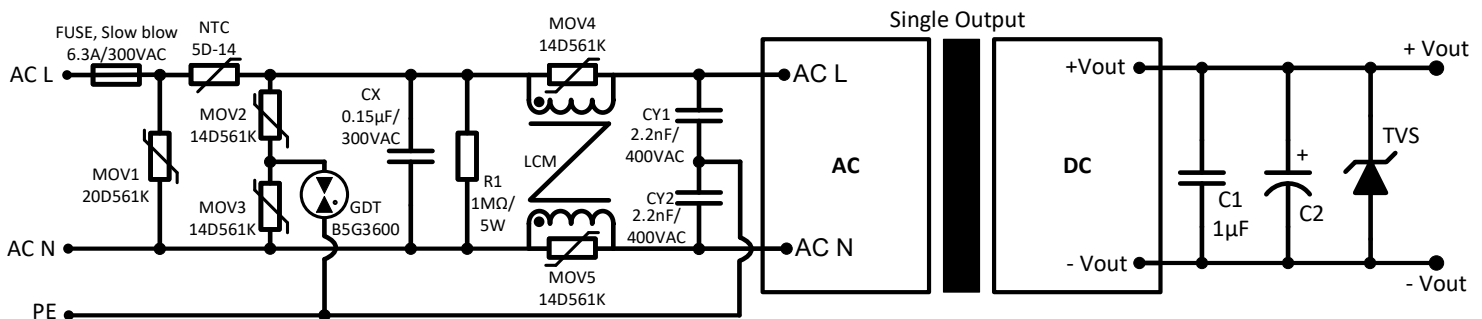

Model	LCM	C2	TVS
12, 15Vout	AMFC22-3NZ	330μF	20V
24Vout	AMFC22-3NZ	200μF	30V
48Vout	AMFC22-3NZ	100μF	64V

Dimensions

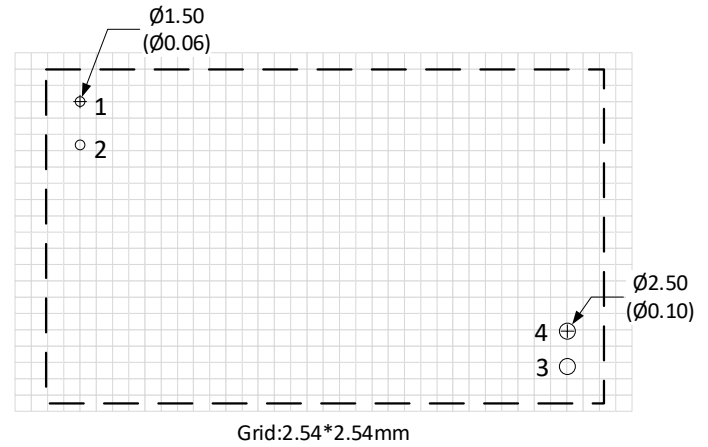
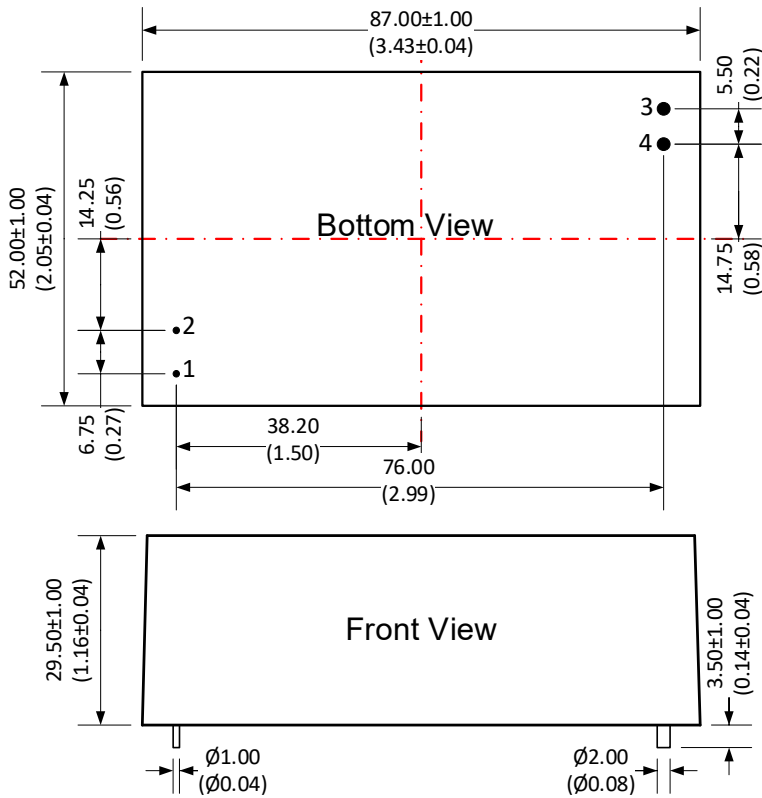

Dimensions mm (inch).
Pin diameter tolerance ± 0.1 (± 0.004)
General tolerance ± 0.5 (± 0.02)

Pin Output Specifications

Pin	Function
1	AC Input (N)
2	AC Input (L)
3	+V Output
4	-V Output

NOTE: 1. Datasheets are updated as needed and as such, specifications are subject to change without notice. Once printed or downloaded, datasheets are no longer controlled by Aimtec; refer to www.aimtec.com for the most current product specifications. 2. Product labels shown, including safety agency certifications on labels, may vary based on the date manufactured. 3. Mechanical drawings and specifications are for reference only. 4. All specifications are measured at an ambient temperature of 25°C, humidity<75%, nominal input voltage and at rated output load unless otherwise specified. 5. Aimtec may not have conducted destructive testing or chemical analysis on all internal components and chemicals at the time of publishing this document. CAS numbers and other limited information are considered proprietary and may not be available for release. 6. This product is not designed for use in critical life support systems, equipment used in hazardous environments, nuclear control systems or other such applications which necessitate specific safety and regulatory standards other than the ones listed in this datasheet. 7. Warranty is in accordance with Aimtec's standard Terms of Sale available at www.aimtec.com.